



AUGUSTO
DYNAMIC CLOSET

AUGUSTO

The revolutionary way
to organize your wardrobe

It reinvents the traditional wardrobe, transforming it from a static to a dynamic system. Its elegant design makes it ideal for different architectural contexts, blending nicely with any existing furnishings. It can wonderfully integrate with the components of an existing walk-in-closet.

Augusto is perfectly in line with the contemporary space requirements of modern homes, optimizing space

as garments, that are usually stored on a single line, are here stored on two parallel lines, purposely designed in order to make the garments rotate in a minimum space. At the same time, garments and accessories are always tidy and handy. Each Augusto system is individually made in Italy according to the customers' specifications.

Thus, it is available in a wide range of colors and finishes, e.g. enamel, wood or leather. Dynamic shelves, drawers and elements are personalized to suit each individual customer, just like the best tailor-made suit made individually in the best Italian design tradition.

Technical information

It consists of a shelf, which can be borne by two side panels or be installed in an existing closet.

The stainless steel belt and the motor are placed into the underside of the dynamic shelf.

The movement can be activated by a switch or a remote control, smartphone or tablet, but the system can also be effortlessly rotated by hand.

The system is totally noiseless and vibration-free.

The capacity depends on the kind and the volume of garments, but the average capacity is about 10/15 garments for one foot.

Augusto®

AUTOMATED CLOSET
WITH AUGUSTO SYSTEM INTEGRATED

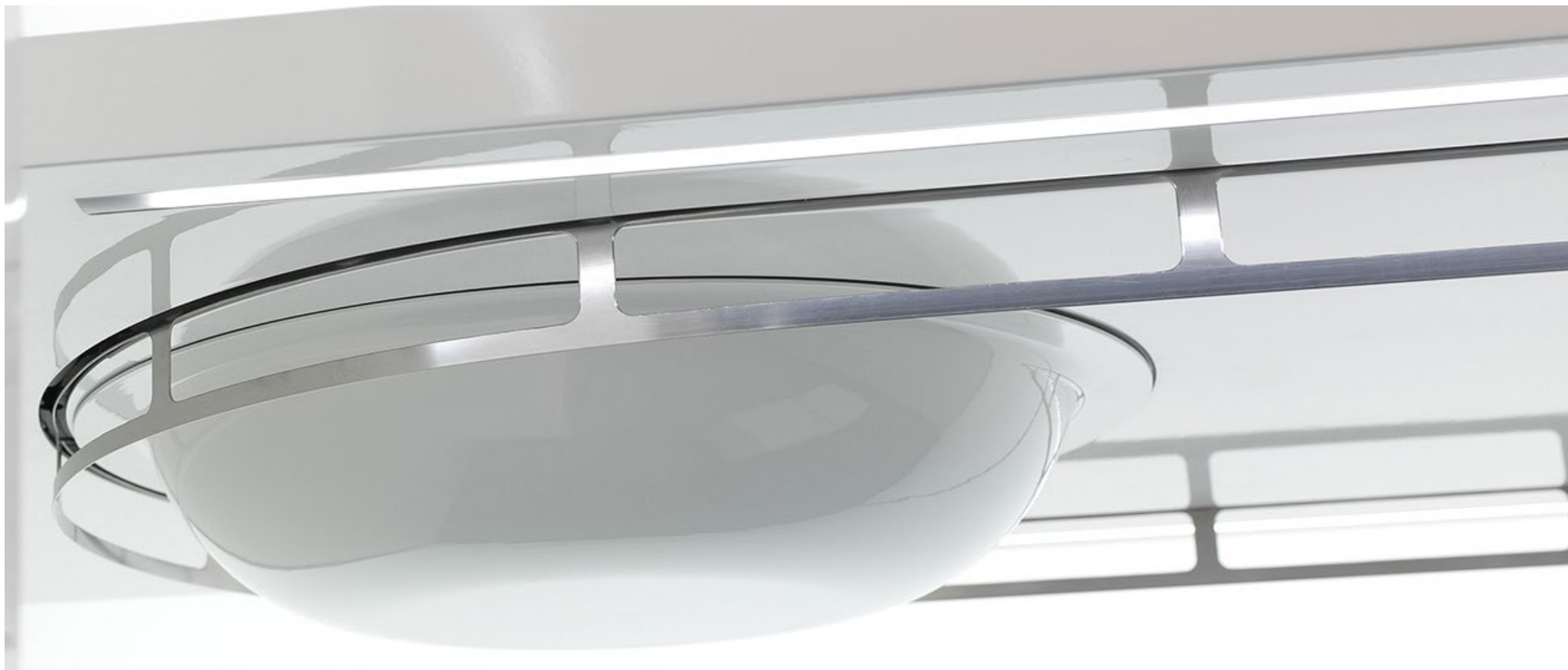

Augusto®

EXAMPLE OF AUTOMATED CLOSET
WITH AUGUSTO SYSTEM INTEGRATED



IDEAS AND DESIGNS

Augusto®

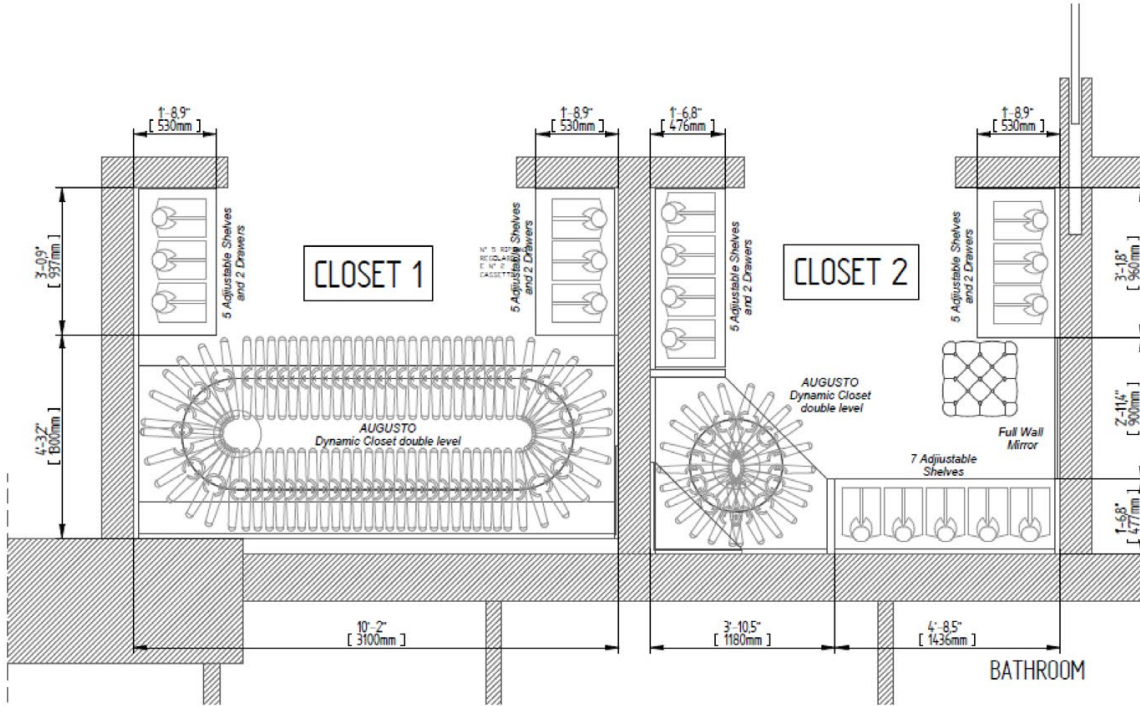
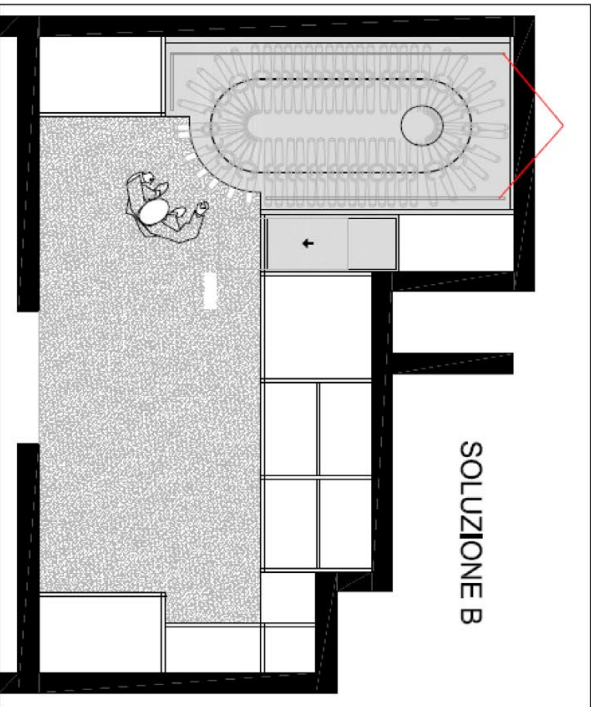

LAY-OUT EXAMPLES

Augusto®

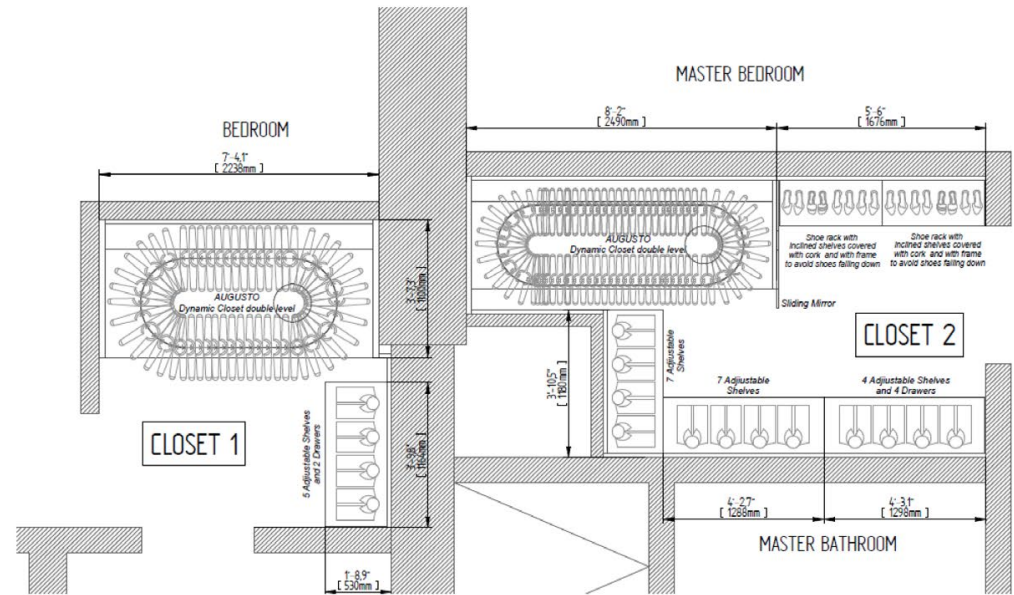
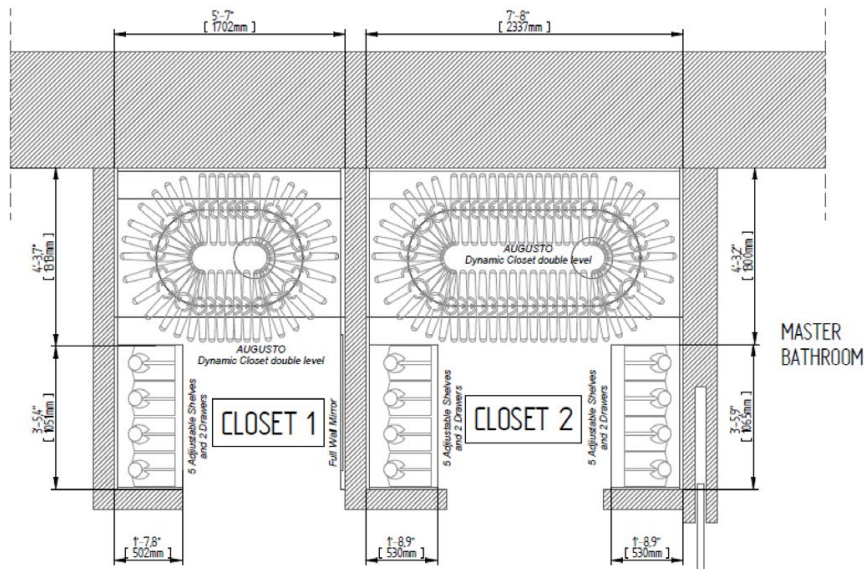

LAY-OUT EXAMPLES

Augusto[®]

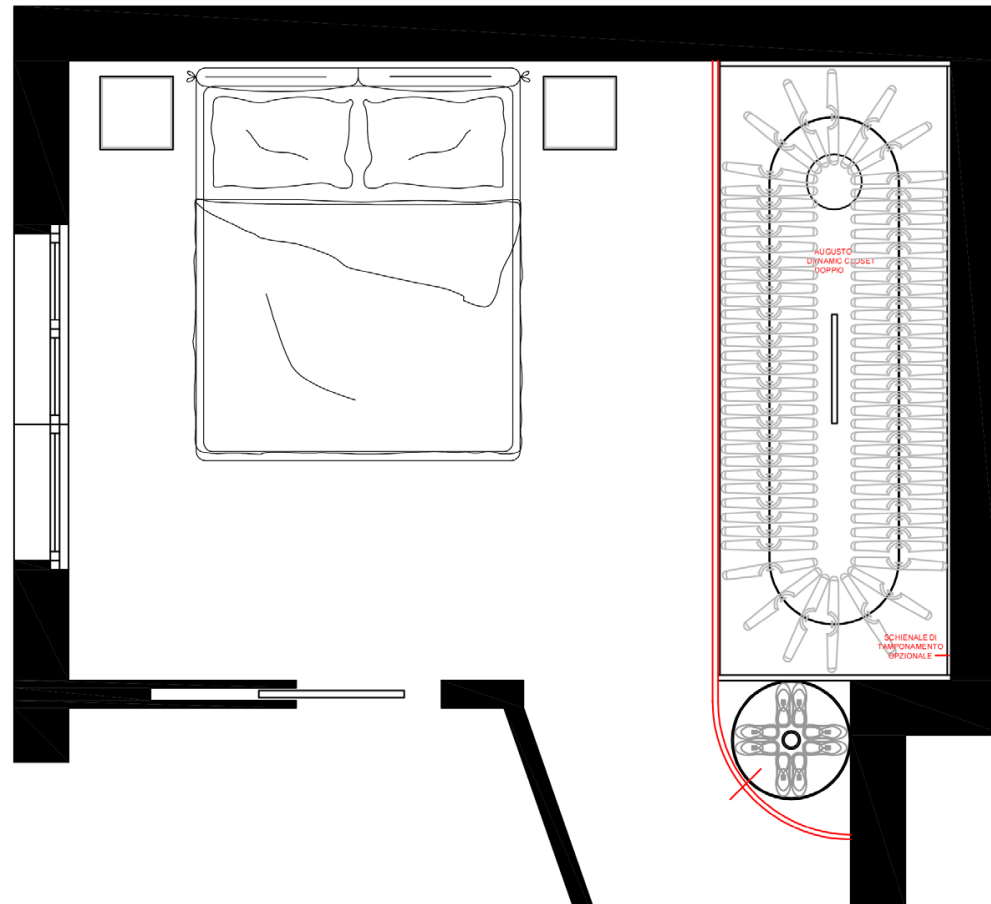

LAY-OUT EXAMPLES

Augusto®



IDEAS AND DESIGNS

Augusto®



IDEAS AND DESIGNS

Augusto[®]



SHOE RACK

Augusto[®]



Revolving Shoe Rack.

The unit consists of customized shelves which are 1 meter in Diameter and each shelf can hold 10-14 pairs of shoes, depending on size. Shelves have a cork finish to prevent sliding.

The height, number of shelves, and depth can be customized to fit the needs of the customer.

The height of the shelves is adjustable as well. The motor is placed above in the cabinet but does not encompass the entire space. The height of the unit is dependent on the space.

Augusto®

POSSIBLE ELEMENTS OF THE CLOSET

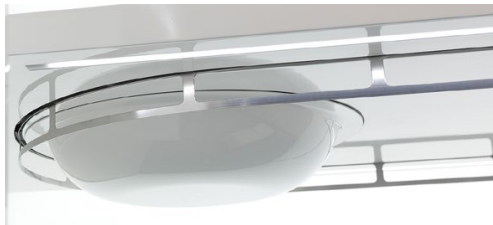
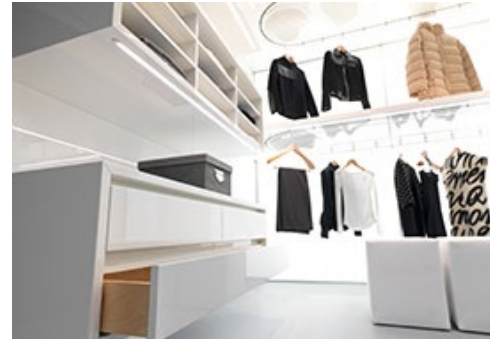

Augusto[®]

FINISHES

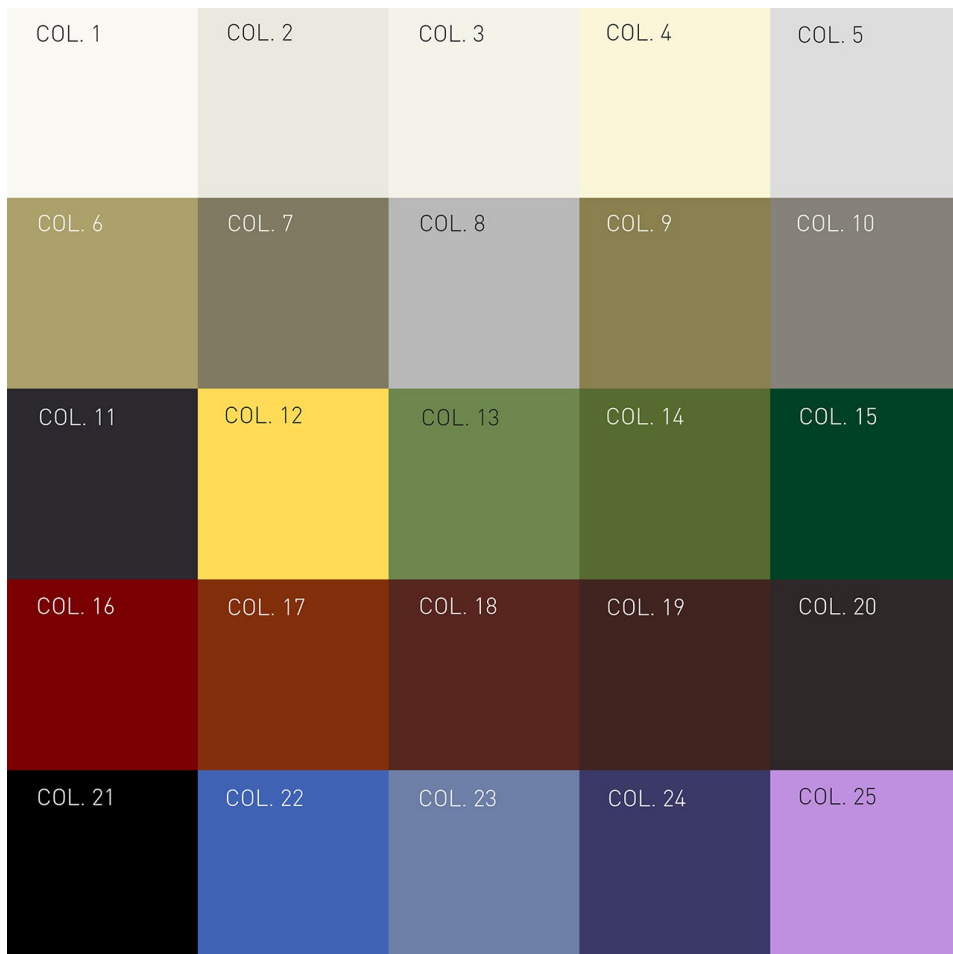

COLORS

SOME EXAMPLES OF COLORS.
AUGUSTO PRODUCTS ARE CUSTOMIZABLE
WITH ALL THE RAL COLORS, GLOSSY OR MAT.

Augusto®

FINISHES



NATURAL WOOD

ALL AUGUSTO PRODUCTS ARE HANDMADE WITH DIFFERENT KINDS OF WOOD.



Augusto®

FINISHES

NATURAL LEATHER

ALL AUGUSTO PRODUCTS ARE HANDMADE WITH NATURAL OR FAUX LEATHER IN DIFFERENT COLORS.



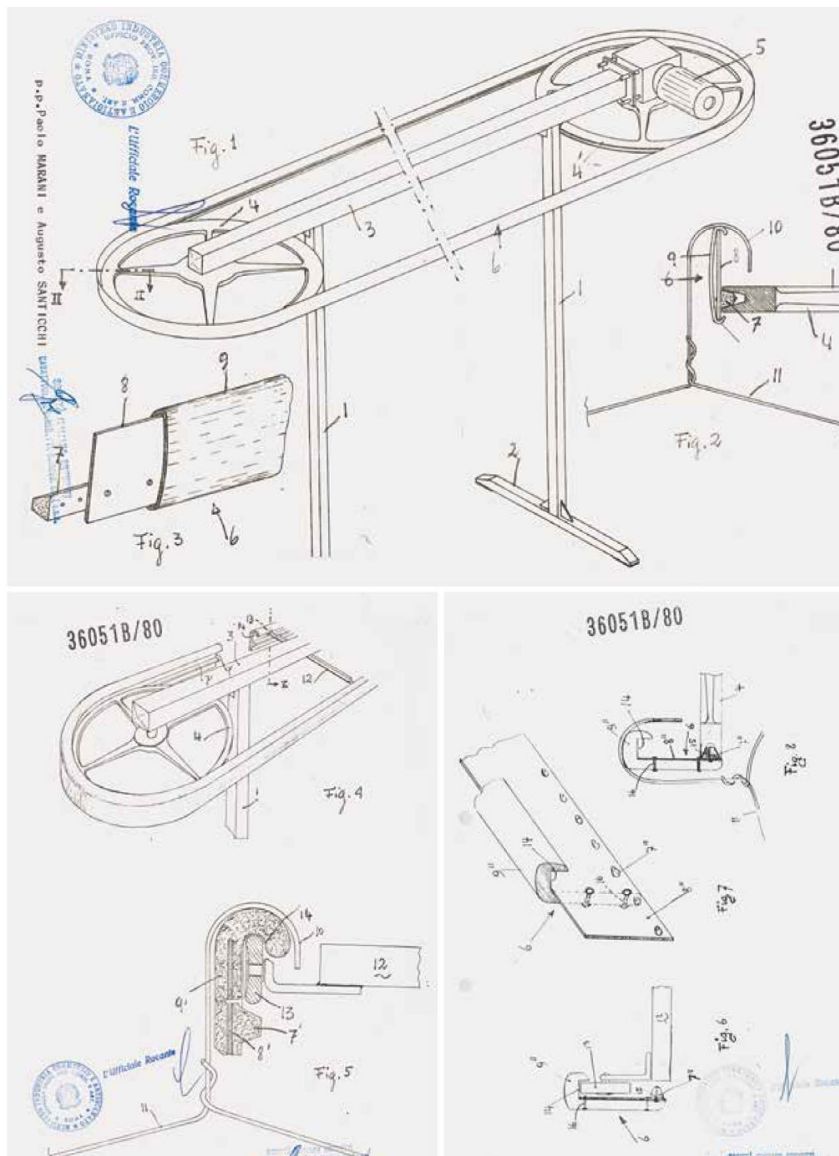

Above: sketches for patent N.182724 for the invention of a "Conveyor belt for conveying and storing garments", granted to Augusto Santicchi and Paolo Marani and applied for on May 19 1978.

AUGUSTO

A new step in a long successful story

Based in Perugia, Italy, Metalprogetti is a leading company in the design and manufacture of automated systems for the handling of garments.

It all started at the end of the 70s when the founder of the company, Augusto Santicchi, invented Quick, a modern and efficient system for handling garments in industrial laundries.

Quick was a real revolution: the old rattling systems were replaced by this functional, clever and harmonious product of minimalist shapes, perfectly suited to the aesthetic taste of the time. The business started to grow and in 1985 Metalprogetti built a new plant which was later expanded.

From now on, research and innovation have been key words at Metalprogetti: the invention of the steel belt C/70 led to the design of large-scale systems on several levels, meeting the request of storing as many garments as possible in the space available. The precision of the mechanical movement revealed itself very precious when adding sophisticated automations and electronic devices. Nowadays, Metalprogetti systems are to be found in hotels, accommodation facilities and the fashion industry worldwide.

Still bearing functional design in mind, in 2014 Metalprogetti invented "Augusto, the dynamic closet", which holds years of work and experience combined with an elegant design. Augusto is not only a space-saving solution and a sophisticated closet: it is also a new home design concept.

Augusto®

Mutagenesis Metalprogetti



70

Quick, a unique example of its kind, presented to sales representative in 1978, patented with N.182724. It's here that it all started for Metalprogetti, and this product also had a strong influence on the technological and management changes that were on their way in dry-cleaning businesses.



80

It wasn't enough just to convey garments on a line, the exact position of each single hanging garment also needed to be known: this is how the "loop belt" solution was invented, with slots as space divisions.



90

This wasn't enough either, so more complex solutions were created in different shapes and on several levels, in order to meet the growing needs for large storage capacities using as little space as possible.



00

A sort of "cash dispenser" for garments was sought after, both for everyday wear and for work wear. So B2K was invented, a completely automatic system for dropping off garments requiring cleaning and picking up cleaned garments.



Now

After having designed wardrobe solutions for royal palaces and some of the powerful of this world, Metalprogetti's research and innovation department came up with the dynamic shelf, a high-quality product for a demanding market.

Ever since 1980, **Metalprogetti's** systems have been used for prestigious installations and important events.

Metalprogetti's automated systems for handling garments are used not only by industries, but also by several famous fashion brands to present their new collections, by important museums to display historical costumes, and by television production companies to use in films or adverts.



Museum BL di Liestal

Exhibit installation Hanro
Historical collection.
Museum BL in Liestal,
Switzerland.

MOST Milano

Installazione espositiva
Nuova Collezione
Adidas. Settimana del
Design, MOST / Milano.

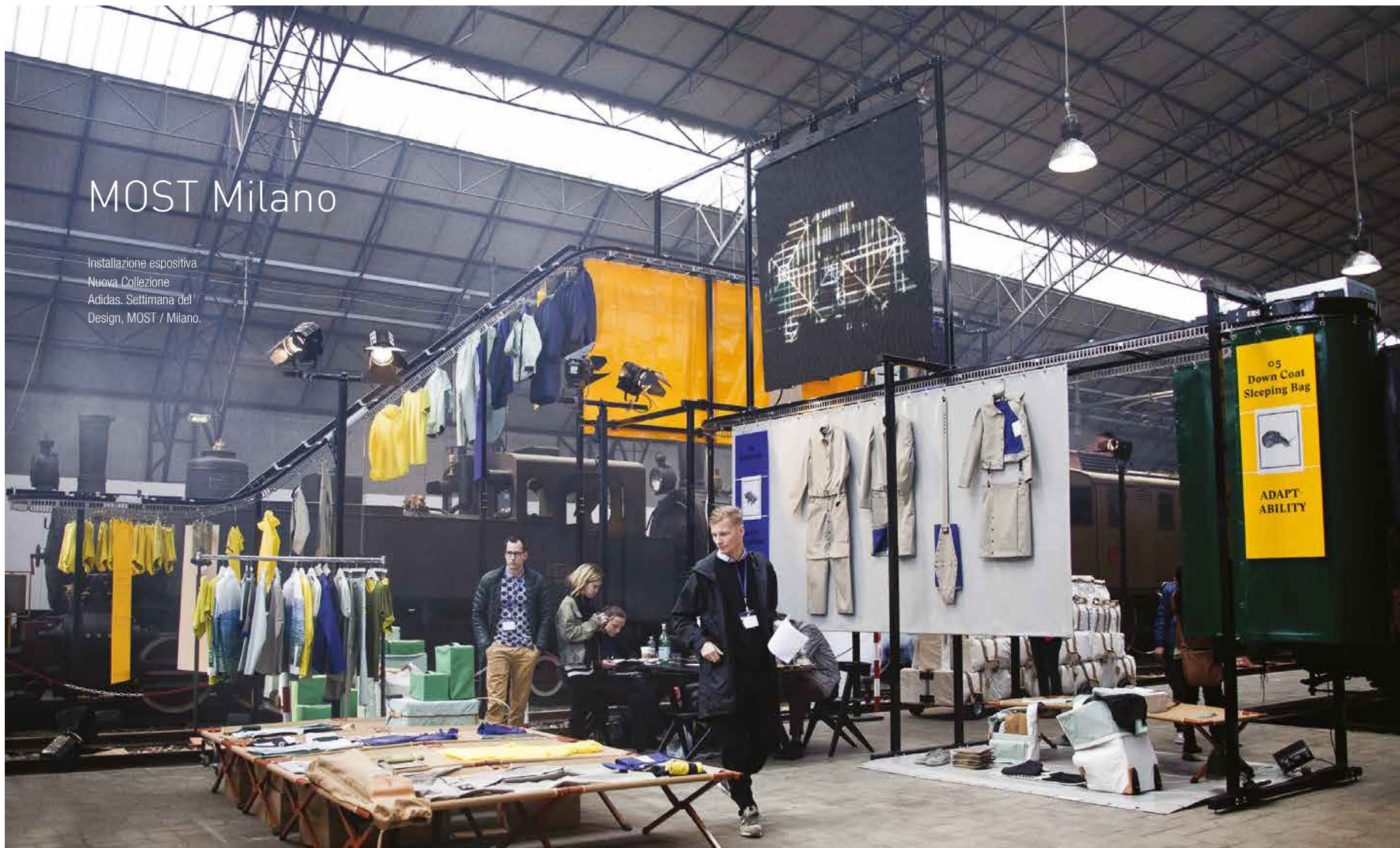



Exhibit installation Gucci



Industrial installation, Max Mara



Exhibit installation 'Luxury Carousel',
Via Sant'Andrea 8, Fuorisalone, Milan